

INCH-POUND
ATPD 2295A
1 February 2007
SUPERSEDING
ATPD 2295
8 June 2000

PERFORMANCE PURCHASE DESCRIPTION
DRUMS, FABRIC-REINFORCED, COLLAPSIBLE: (DRINKING WATER; 500, 250, AND
55 GALLON CAPACITIES, AND FUEL, 500 GALLON CAPACITY)

1. SCOPE

1.1 Scope. This specification covers collapsible fabric-reinforced drums for storing, transporting, and dispensing drinking water or fuel.

1.2 Classification. The drums will be of the following Types as specified (see 6.2).

1.2.1 Class I. Potable Water.

- Type I - 500 gallon capacity, 58 inches long, with two, 2-inch filler/discharge.
- Type IA - 500 gallon capacity, 58 inches long, with two, 4-inch filler/discharge.
- Type II - 250 gallon capacity, with one, 1-1/2-inch filler/discharge.
- Type III - 55 gallon capacity, with faucet and fill port fitting(s).

1.2.2 Class II. Fuel.

- Type I - 500 gallon capacity, 78 inches long, with a fuel/defuel valve and a 2-inch filler/discharge.
- Type II - 500 gallon capacity, 58 inches long, with one, 1-1/2 inch filler/discharge.
- Type III - 500 gallon capacity, 58 inches long with two, 1-1/2 inch filler/discharge.

2. APPLICABLE DOCUMENTS

2.1 General. The documents listed in this section are specified in sections 3 and 4 of this specification. This section does not include documents cited in other sections of this specification or recommended for additional information or as examples. While every effort has been made to ensure the completeness of this list, document users are cautioned that they must meet all specified requirements documents cited in sections 3 and 4 of this specification, whether or not they are listed.

Beneficial comments, suggestions, or questions on this document should be addressed to U.S. Army Tank-automotive and Armaments Command, 6501 E. 11 Mile Road, Warren, MI 48397-5000 or emailed to standardization@tacom.army.mil.

2.2 Government documents.

2.2.1 Specifications, standards, and handbooks. The following specifications, standards, and handbooks form a part of this document to the extent specified herein. Unless otherwise specified, the issues of these documents are those listed in the issue of the Department of Defense Index of Specifications and Standards (DoDISS) and supplement thereto, cited in the solicitation (see 6.2).

SPECIFICATIONS

FEDERAL

- A-A-52557 - Fuel Oil, Diesel; For Posts, Camps and Stations.
- A-A-59326 - Coupling Halves, Quick-Disconnect, Cam-Locking Type

MILITARY

- MIL-DTL-83133 - Turbine Fuels, Aviation, Kerosene Types, NATO F-34 (JP-8), NATO F-35, and JP-8 +100.

STANDARDS

MILITARY

- MIL-STD-814 - Requirements for Tiedown, Suspension and Extraction Provisions on Military Material for Airdrop
- MIL-STD-209 - Interface Standard for Lifting and Tiedown Provisions
- MIL-STD-913 - Requirements for the Certification of Sling Loaded Military Equipment for External Transportation by Department of Defense Helicopters

(Unless otherwise indicated, copies of the above specifications, standards, and handbooks are available from the Standardization Document Order Desk, 700 Robbins Avenue, Building 4D, Philadelphia, PA 19111-5094, or at <http://assist.daps.dla.mil/online/start/>).

2.2.2 Other Government documents, drawings, and publications. The following other Government documents, drawings, and publications form a part of this purchase description to the extent specified herein. Unless otherwise specified, the issues are those cited in the solicitation.

- ATPD 2263 - Repair Kit and Repair Kit Components, For Collapsible Fabric Tanks and Drums

(Unless otherwise indicated, copies of the above purchase description are available from the preparing activity or directly from the contracting officer, or from standardization@tacom.army.mil).

FOOD AND DRUG ADMINISTRATION (FDA)
21 CFR 177.2600 - Code of Federal Regulations

(Code of federal Regulations (CFR) and Federal Register (FR) are for sale on a subscription basis by the Superintendent of Documents, U.S. Government Printing Office, Washington, DC 20402. When indicated, reprints of certain regulations may be obtained from the Federal Agency responsible for issuance thereof, or at www.fda.gov).

DRAWINGS

13229E8595 - Adapter Assembly

(Unless otherwise indicated, copies of the above drawing are available from the preparing activity or directly from the contracting officer).

2.3 Non-Government publications. The following documents form a part of this document to the extent specified herein. Unless otherwise specified, the issues of the documents which are DoD adopted are those listed in the issue of the DoDISS cited in the solicitation. Unless otherwise specified, the issues of the documents not listed in the DoDISS are the issues of the documents cited in the solicitation (see 6.2).

AMERICAN PUBLIC HEALTH ASSOCIATION (APHA)

APHA SME - Standard Methods for the Examination of Water and Wastewater.

(Applications for copies should be addressed to the American Public Health Association, 1015 15th Street NW, Washington, DC 20005, or at www.apha.org).

AMERICAN SOCIETY FOR TESTING AND MATERIALS (ASTM)

- ASTM D 381 - Existent Gum in Fuels by Jet Evaporation (DoD Adopted).
- ASTM D 412 - Vulcanized Rubber and Thermoplastic Rubbers and Thermoplastic Elastomers – Tension (DoD Adopted).
- ASTM D 471 - Rubber Property – Effect of Liquids (DoD Adopted).
- ASTM D 573 - Rubber – Deterioration in an Air Oven (DoD Adopted).
- ASTM D 751 - Coated Fabrics (DoD Adopted).
- ASTM D 814 - Rubber Property – Vapor Transmission of Volatile Liquids (DoD Adopted).
- ASTM D 1171 - Rubber Deterioration – Surface Ozone Cracking Outdoors or Chamber (Triangular Specimens) (DoD Adopted).
- ASTM D 2137 - Rubber Property – Brittleness Point of Flexible Polymers and Coated Fabrics (DoD Adopted).

(Application for copies should be addressed to the American Society for Testing and Materials, 1916 Race Street, Philadelphia, PA 19103, or at www.astm.org).

SOCIETY OF AUTOMOTIVE ENGINEERS

SAE AS5877 - Detailed Specification for Aircraft Pressure Refueling Nozzle

(Application for copies should be addressed to the SAE, 400 Commonwealth Drive, Warrendale, PA 15096-0001, or at www.sae.org).

NATIONAL SANITATION FOUNDATION (NSF)

NSF 61 - Drinking Water Systems Components – Health Effects (DoD Adopted).

(Application for copies should be addressed to the National Sanitation Foundation, 3475 Plymouth Rd., PO Box 1468, Ann Arbor, MI 48106, or at [http://www.healthgoods.com/Shopping/Water Quality Products/National Sanitation Foundation Standards 3.htm](http://www.healthgoods.com/Shopping/Water_Quality_Products/National_Sanitation_Foundation_Standards_3.htm)).

2.4 Order of precedence. In the event of a conflict between the text of this document and the references cited herein, the text of this document takes precedence. Nothing in this document, however, supersedes applicable laws and regulations unless a specific exemption has been obtained.

3. REQUIREMENTS

3.1 Description. The drums shall store, transport, and dispense drinking water or fuel to the capacities specified in section 1. The drums shall be collapsible and non-vented. Class I drums shall be compatible with drinking water. Class II drums shall be compatible with fuel in accordance with A-A-52557 (diesel fuel) and MIL-DTL-83133 (JP-8). Manually-controlled valves and fittings shall be provided for filling and dispensing drinking water. Means for suspending/lifting and tying down the drums shall be provided on either end of the drums. On 250 and 500 gallon drums attachment points shall provide the ability for roll-towing the drums for short distances. When specified (see 6.2), emergency repair kits shall be furnished with each drum. The drums shall be capable of operating in a temperature range of -25°F to 130°F without leaking. The drums shall be capable of storage in temperatures ranging of -28°F to 160°F without damage to the assembly. Figures A1 and A2 are provided for guidance only and do not contain any mandatory requirements.

3.2 First article. When specified (see 6.2), a sample shall be subjected to first article inspection in accordance with 4.2.

3.3 Materials. Materials shall be selected by the contractor and shall be subject to all provisions of this specification. Materials selected shall meet or exceed the requirements specified herein and shall be sufficient to withstand the rigors of daily use in the applicable operating and storage environments to which the drums may be exposed, without suffering the effects of deterioration. The contractor shall provide a certification for Class I drums that all

surfaces that contact drinking water shall comply with the requirements of the Code of Federal Regulations (21 CFR 177.2600) or NSF 61.

3.3.1 Material deterioration prevention and control. The drums shall be fabricated from compatible materials, inherently resistant to deterioration or treated to provide protection against the various forms of deterioration to which they may be susceptible. Metals used in the construction of the drums shall be of a corrosion-resistant type or be suitably protected to resist corrosion during the normal service life of the drums and shall be suitably finished for use with drinking water or fuel as required. Dissimilar metals shall not be used in intimate contact with each other unless protected against galvanic corrosion.

3.3.2 Class I liner materials. Materials for fabrication of Class I drums shall meet or exceed the requirements of Table I.

Table I. Characteristics of liner material for Class I drums.

Test Item	Test Property	Requirement (all drum sizes)		Test Method
		Inner Liner	Outer Liner	
1.	Initial properties: Tensile strength Ultimate elongation	1450 psi (min) 300% (min)	1450 psi (min) 300% (min)	ASTM D 412 die C
2.	Water resistance after immersion in test fluid at 212° F for 70 hours: Volume change	10% (max)	-	ASTM D 471
3.	Low-temperature resistance after immersion in test medium; brittleness 3 minutes at -40° F	Non-brittle	Non-brittle	ASTM D 2137 Method A
4.	Heat resistance after exposure to test at 212° F for 70 hours: Tensile strength retained Elongation retained Hardness change	80% (min) 60% (min) +15 pts (max)	85% (min) 60% (min) +15 pts (max)	ASTM D 573
5.	Taste rating level	Max No. 4	-	APHA SME 2160 B
6.	Odor threshold	Max. No.2	-	APHA SME 2150 B
7.	Ozone resistance: Quality retention	-	85% (min)	ASTM D 1171 Method A

3.3.3 Class II liner materials. Materials for fabrication of Class II drums shall meet or exceed the requirements of Table II.

Table II. Characteristics of liner material for Class II drums.

Test Item	Test Property	Requirement (all drum sizes)		Test Method
		Inner Liner	Outer Liner	
1.	Initial properties: Tensile strength Ultimate elongation	1450 psi (min) 300% (min)	1450 psi (min) 300% (min)	ASTM D 412 die C
2.	Fuel resistance after immersion in test fluid at 74 ± 2° F for 70 hours: Volume swell	40% (max)	40% (max)	ASTM D 471 Ref. Fuel B
3.	Low-temperature resistance after immersion in test medium; brittleness 3 minutes at -40° F	Non-brittle	Non-brittle	ASTM D 2137 Method A
4.	Heat resistance after exposure to test at 212° F for 70 hours: Tensile strength retained Elongation retained Hardness change	80% (min) 60% (min) +15 pts (max)	85% (min) 60% (min) +15 pts (max)	ASTM D 573
5.	Ozone resistance: Quality retention	-	85% (min)	ASTM D 1171 Method A

3.3.4 Class II drum wall materials. Materials for fabrication of Class II drum wall shall meet or exceed the requirements of Table III.

Table III. Characteristics Class II drum wall material.

Test Item	Test Property	Requirement (all drum sizes)	Test Paragraph
1.	Permeability rate (fl oz/sq ft/24 hr, maximum)	0.10	4.5.4
2.	Unwashed gum (mg/100 mL, maximum)	60	4.5.5
3.	Existent gum content (mg/100 mL, maximum)	5	4.5.6

Test Item	Test Property	Requirement (all drum sizes)	Test Paragraph
4.	Coating adhesion Initial (lb/in, minimum)	10	4.5.7
	After fuel immersion for 70 hours (lb/in, minimum)	5	

3.4 Physical characteristics.

3.4.1 Puncture resistance. The 250 and 500 gallon drum walls shall withstand a force of not less than 325 pounds without being punctured. The 55 gallon drum wall shall withstand a force of not less than 200 pounds without being punctured (see 4.6.8).

3.4.2 Weight. When empty the weight of the completely assembled drum shall not exceed the following when tested in accordance with 4.6.9:

<u>Class I</u>		<u>Class II</u>	
Type I	- 275 pounds	Type I	- 315 pounds
Type IA	- 300 pounds	Type II	- 275 pounds
Type II	- 240 pounds	Type III	- 300 pounds
Type III	- 50 pounds		

3.4.3 Expansion dimensions (excluding Class I – Type III). Drum dimensional changes shall not exceed the following when subjected to a pressure of 30 psig for 7 hours:

Overall length	-	1.00 inch
Diameter	-	6.00 inches

3.5 Performance characteristics.

3.5.1 Ultimate pressure. Except for Class I - Type III drums, all drums shall withstand an ultimate pressure of 45 pounds force per square inch gage (psig) without any leakage, external or internal component layer separation, delamination propagation or blistering. Class I - Type III drums shall withstand 35 psig, without any leakage, external or internal component layer separation, delamination propagation or blistering.

3.5.2 Proof pressure. Except for Class I - Type III drums, all drums shall withstand a hydrostatic pressure of 30 psig without any leakage. Class I - Type III drums shall withstand a hydrostatic pressure of 20 psig without any leakage.

3.5.3 Ambient temperature collapsibility. The drum shall be filled and emptied through 75 cycles in an ambient temperature range of between 60 and 90 °F, without any leakage, external or internal blistering, delamination, splits, cracks, or chipping.

3.5.4 Leakage. Each drum shall withstand the leakage test specified in 4.6.14 without leakage.

3.5.5 Drop. When full of water, the Class I drum (excluding the Class I - Type III drum) shall be capable of withstanding six successive drops from a height of not less than 5 feet. When full of water, each Class II drum shall be capable of withstanding six successive drops from a height of not less than 12.7 feet.

3.5.6 Rolling tow. All drums (excluding the Class I - Type III drum) shall be capable of being towed as a wheel for 20 miles over paved road in less than 4 hours without leakage or damage to the drum when tested as specified in 4.6.16.

3.5.7 Fuel storage. The Class II drums shall withstand the 72 hour fuel storage test without any visual evidence of leakage, inner or outer liner separation, cracks, splits, or deterioration.

3.6 Fittings. Each drum shall be furnished with required fittings for controlling filling and dispensing operations, and for supporting the tow, lift, and tiedown attachment points.

3.6.1 Filler/discharge assembly. Each filler/discharge assembly shall consist of a manually-controlled coupler valve and an adapter fitting containing a check valve. The check valve within the adapter fitting shall close when the coupler valve is removed. A dust cap shall be attached to the adapter fitting to prevent foreign matter from entering the adapter and drum assembly. One end of the coupler valve shall interface with the adapter. The other end of the coupler valve shall interface with a male hose fitting. The hose fitting shall be a male coupling half in accordance with figure 2 of A-A-59326. The corresponding drum, nominal size cam-lock and quantity of filler/discharge assemblies shall be as specified in Table IV.

Table IV. Filler/discharge ports.

Drum Classification	Nominal Size IAW A-A-59326	Quantity of Filler/Discharge Assembles per Drum
Class I, Type I	2-inch	2
Class I, Type IA	4-inch	2
Class I, Type II	1-1/2-inch	1
Class II, Type I (1)	2-inch	1
Class II, Type II	1-1/2-inch	1
Class II, Type III (2)	1-1/2-inch	2

(1) In addition to the filler/discharge assembly, this drum requires a fuel/defuel valve (see 3.6.3).

(2) The coupler valve shall be capable of form, fit and functional interface with adapter fittings on fielded drums in accordance with 13229E8595 (see 6.4)

3.6.2 Faucet valve and fill port fitting for 55gallon drum. Each Class I - Type III drum shall have one faucet valve and fill port. The fitting shall be installed in a manner that allows the drum to roll as a wheel without damage to the drum or fitting. The faucet valve shall allow for dispensing into a standard military canteen (1-inch nominal diameter opening). The faucet valve

shall incorporate into its design a tethered cap or plug to prevent foreign matter from entering drum assembly The fill port shall have a nominal 2-inch diameter opening.

3.6.3 Fuel/defuel valve. Each Class II - Type I drum shall be equipped with a fuel/defuel valve which shall permit filling and emptying of the drum by means of a D-1 nozzle conforming to SAE AS5877 in addition to the filler/discharge assembly of 3.6.1. The fuel/defuel valve shall be capable of performing the fuel/defuel cycle to either shut off flow to the drum upon reaching an internal pressure of 4.5 ± 0.5 psig above local atmospheric pressure, or to open upon the application of a negative pressure at the adapter inlet. The valve shall be fitted with a pressure fuel-servicing adapter. The fuel/defuel valve shall neither extend externally more than 1.125 inches beyond the bearing plate nor extend internally more than 3.250 inches beyond the inside face of the closure plate. All surfaces of the valve that shall contact the drum shall be smooth and rounded with no sharp edges or radii smaller than 0.5 inch. The fuel/defuel valve shall be provided with a dust cap to fit over the adapter opening. The dust cap shall be tethered to the fuel/defuel valve by means of a cable, chain, or other suitable means.

3.6.4 Transportability fittings.

a. When completely assembled and filled to rated capacity, the drums shall be capable of being airlifted by cargo helicopter and towed by, or transported in, wheeled cargo vehicles. The 55-gallon drum shall be excluded from the tow requirement, but shall be capable of being rolled like a wheel by hand. The drums shall not degrade the safe operation of the vehicle when being airlifted, towed, or transported. Each drum shall be equipped with fittings capable of meeting the transport mode. The 55-gallon drum shall have a minimum of two lifting/tiedown fittings. The 250 and 500-gallon drums shall have a minimum of four lifting/tiedown/tow fittings.

b. The transportability fittings for 250 gallon and 500 gallon Class I (water) and Class II (fuel) drums shall be rated for Helicopter Sling Lift (HSL) and for Low Velocity Air Drop (LVAD) based on the maximum weights shown below in Table V. Transportability fittings shall meet or exceed the requirements of Table V.

Table V. Characteristics of transportability fitting.

Drum Capacity (Gallons)	Maximum Filled Weight (Lbs.)	Minimum Safe Working Load (Lbs.)	Ultimate Strength (Lbs.)	A rod with a minimum diameter capable of passing through the lifting/tiedown/tow fitting. (Inches)
55	Water 500	500	750	1
250	Water 2250	Note 1	Note 1	1-1/16
500	Water 4450 / Fuel 3700	Note 1	Note 1	1-5/8

Note 1: LVAD tiedown requirements shall be as specified in Mil-Std-814D. LVAD requirements per Mil-Std-814D shall be required to be demonstrated to obtain a LVAD certification for the drum. HSL lifting requirements shall be as specified in Mil-Std-209K. The requirements of Mil-STD-913A for HSL shall be required to be demonstrated to obtain a HSL certification for the drum. Test methods and results for LVAD and HSL certification shall be approved by the U.S. Army Natick Research, Development and Engineering Center, ATTN: SSCNC-UTE, Natick, MA 01760-5017. The contractor shall contact Natick to obtain a LVAD and HSL certification.

3.7 Identification marking.

3.7.1 Class I drum markings. The 55 gallon water drum shall have a 2-inch wide blue stripe permanently marked around wall of the drum. This blue strip shall be located at the center of the on the drum wall. The following markings shall be located and repeated on each reinforced end of all drums. Each drum shall be permanently and legibly marked in blue letters as specified below:

DRINKING WATER ONLY	(Minimum 4-inch height and all capitol letters for 500 and 250 gallon drums. Minimum 2-inch height and all capitol letters for 55 gallon drums.)
55/250/500 Gallon Capacity	(Appropriate capacity in minimum .75-inch height letters for all drums.)
MAX 5 PSI	(Minimum .75-inch height letters for all drums.)
# x # Inches	(Appropriate length and width in inches with minimum .75-inch height letters for all drums.)
Empty Weight # lbs.	(Appropriate weight in pound with minimum .75-inch height letters for all drums.)
MFRS (name)	(Appropriate name in minimum .75-inch height letters for all drums.)
Contract #	(Appropriate contract number in minimum .75-inch height letters for all drums.)
DOM MM/YY	(Appropriate date of manufacture in two digit month and year in minimum .75-inch height letters for all drums.)

3.7.2 Class II drum markings. The following markings shall be located and repeated on each reinforced end. The drum shall be permanently and legibly marked in yellow letters as specified below:

FLAMMABLE	(Minimum 4-inch height and all capitol letters for 500 and 250 gallon drums. Minimum 2-inch height and all capitol letters for 55 gallon drums.)
500 Gallon Fuel Drum	(Minimum .75-inch height letters for all drums.)
MAX 5 PSI	(Minimum .75-inch height letters for all drums.)
# x # Inches	(Appropriate length and width in inches with minimum .75-inch height letters for all drums.)

Empty Weight # lbs.	(Appropriate weight in pound with minimum .75-inch height letters for all drums.)
MFRS (name)	(Appropriate name in minimum .75-inch height letters for all drums.)
Contract #	(Appropriate contract number in minimum .75-inch height letters for all drums.)
DOM MM/YY	(Appropriate date of manufacture in two digit month and year in minimum .75-inch height letters for all drums.)

3.8 Emergency repair kit. When specified (see 6.2), the drums shall be furnished with an emergency repair kit conforming to ATPD-2263.

3.9 Accessories for Class I- Type II drums. Unless otherwise specified (see 6.2), each 250 gallon drum shall be furnished with a 10 foot hose and dispensing nozzle. All fittings required to connect the hose to the drum filler/discharge shall be included with the accessories. All fittings required to connect the hose to the nozzle shall be included with the accessories. The dispensing end of the nozzle shall have a nominal diameter outlet of 1-inch. A nozzle stand shall be included with the accessories. The open and close function of the nozzle shall be capable of operation with one hand. All accessories shall approximate a sand matte color and shall be suitable for use with drinking water (see 3.3).

3.10 Finish. The exterior of the Class I drums body (wall and reinforced ends) shall approximate a sand matte color. The exterior of the Class II drum body (wall and reinforced ends) shall be black.

4. VERIFICATION

4.1 Classification of inspections. The inspection conditions specified herein are classified as follows:

- a. First article inspection (see 4.2).
- b. Conformance inspection (see 4.3).

4.2 First article inspection. Unless otherwise specified (see 6.2), first article inspection shall be performed on two completely assembled drums, drum body material and drum liner material (see 4.3.3). This inspection shall include the examination of 4.4 and the applicable tests in 4.5.

4.3 Conformance inspection. Each individual drum shall be conformance inspected in accordance with the applicable test in 4.5. Lot sample conformance inspection shall include the examination of 4.4 and the applicable tests in 4.5.

4.3.1 Lot size. A lot shall consist of one month's production of the same Class and Type.

4.3.2 Sampling for examination and tests. One drum of each Class and Type shall be selected at random from each lot for examination of 4.4 and the applicable tests of 4.5.

4.3.3 Drum body and liner material samples. Drum body material samples shall be prepared by production personnel with production floor equipment from the elastomer compounds and cord or fabric used in fabricating the drums of the lot. The drum sample shall be cured equivalent to the drums. Drum inner and outer liner material from stock may also be used as long as it is taken from production materials of the corresponding lot.

4.4 Examination. Non-compliance with any specified requirement, or the presence of one or more defects shall constitute cause for rejection.

Table VI. Examination Schedule.

Item #	Examination Description	Requirement Paragraph
1.	Materials and certification (Class I only) of compatibility of material with drinking water not as specified.	3.3 & 3.3.1
2.	Fittings not as specified (exclude Class I - Type III).	3.6.1
3.	Fitting not as specified (Class I - Type III only).	3.6.2
4.	Fuel/defuel valve not as specified (Class II - Type I only).	3.6.3
5.	Transportability fittings not as specified.	3.6.4 & table V
6.	Class I drum markings not as specified.	3.7.1
7.	Class II drum markings not as specified.	3.7.2
8.	Emergency repair kit not as specified.	3.8
9.	Class I - Type II drum accessories not as specified.	3.9
10.	Finish not as specified	3.10

4.5 Tests.

Table VII. Test schedule.

First article	Conformance Inspection		Test	Test Paragraph	Requirement Paragraph or Table
	Individual	Lot Sample			
1	2	3	4	5	6
X			<u>Class I Liner Material</u> Tensile strength & elongation	4.6.1	Table 1
X			Water resistance	4.6.1	Table 1
X			Low-temperature resistance	4.6.1	Table 1
X			Heat resistance	4.6.1	Table 1
X			Taste and odor	4.6.2	Table 1
X			Ozone resistance	4.6.1	Table I

			<u>Class II Liner Material</u>		
X			Tensile strength & elongation	4.6.3	Table II
X			Fuel resistance	4.6.3	Table II
X			Low-temperature resistance	4.6.3	Table II
X			Heat resistance	4.6.3	Table II
X			Ozone resistance	4.6.3	Table II
			<u>Class II Drum Wall Material</u>		
X			Permeability	4.6.4	Table III
X			Unwashed gum	4.6.5	Table III
X			Existent gum	4.6.6	Table III
X			Adhesion	4.6.7	Table III
			<u>Physical Characteristics</u>		
X		X	Puncture resistance	4.6.8	3.4.1
X		X	Weight	4.6.9	3.4.2
X		X	Expansion (Except Class I, Type III)	4.6.10	3.4.3
			<u>Performance Characteristics</u>		
X		X	Ultimate pressure	4.6.11	3.5.1
	X		Proof pressure	4.6.12	3.5.2
X			Ambient temperature collapsibility	4.6.13	3.5.3
X	X		Leakage	4.6.14	3.5.4
X		X	Drop (Except Type III)	4.6.15	3.5.5
X			Rolling Tow (Except Type III)	4.6.16	3.5.6
X			Fuel storage (Class II only)	4.6.17	3.5.7
X			Fuel/defuel valve (Class II – Type I only)	4.6.18	3.6.3
X			Transportability	4.6.19	3.6.4

4.6 Testing.

4.6.1 Class I liner material. Liner material properties shall be tested in accordance with test methods shown in Table I. Test samples shall be in accordance with 4.3.3. Nonconformance to table I shall constitute failure and disqualification of the material.

4.6.2 Class I drums, taste and odor. A sample of the drum wall (see 4.3.3) shall be immersed for 70 hours in distilled water having a 0.2 parts per million of total available chlorine at the start of the 70-hour test. The samples shall be large enough to expose 36 square centimeters of compound to one liter of chlorinated distilled water. The material shall not impart odor to chlorinated water to an intensity greater than threshold odor No. 2. The material shall not impart taste to chlorinated water to a rating level higher than 4. The water shall be tested for taste (Part 2160 B) and odor (Part 2150 B) in accordance with procedures outlined in APHA Standard Methods for the Examination of Water and Waste Water. Failure to meet these levels shall constitute failure of this test.

4.6.3 Class II liner material. Liner material properties shall be tested in accordance with test methods shown in Table II. Test samples shall be in accordance with 4.3.3. Nonconformance to table II shall constitute failure and disqualification of the material.

4.6.4 Permeability test (Class II). The permeability test shall be conducted in accordance with ASTM D 814, except that the sample shall be identical in construction and material to the total cross section of the drum and the thickness of the drum wall (see 4.3.3). This test may be performed using an aluminum cup with a suitable clamping device in lieu of the permeability jar specified in ASTM D 814. The test liquid shall be JP-8 in accordance with MIL-DTL-83133. If aluminum cups are used, a nylon solution (Elvamide 8061) can be used to seal the edges. The average of three determinations shall be reported. Nonconformance to table III shall constitute failure of this test.

4.6.5 Unwashed gum (Class II). Cut a 5 gram specimen from the drum interior coating compound (see 4.3.3) into 0.0625 inch squares and place in a flask containing 250 mL of JP-8 in accordance with MIL-DTL-83133 and allow to stand for 48 hours at $73^{\circ} \pm 3^{\circ}$ F. Decant and filter the contaminated fluid through Whatmen 41H filter paper, or equal. Determine the unwashed gum in accordance with section 10 of ASTM D 381 using the air jet vaporizing medium and an evaporation time of 45 minutes. The average of three determinations shall be reported. Nonconformance to table III shall constitute failure of this test.

4.6.6 Existent gum (Class II). Samples from 4.6.5 may be used to determine the heptane-washed existent gum in accordance with section 10 of ASTM D 381. The average of three determinations shall be reported. Nonconformance to table III shall constitute failure of this test.

4.6.7 Adhesion test (Class II). One set of drum material samples (see 4.3.3) shall be tested in accordance with ASTM D 751 for a minimum adhesion of 10 lbs/in. between each layer of the composite drum wall. Examples of layers would be; between the cover and cord plies, between the cord plies, between the inner liner and cord plies and between liners. A second set of drum material samples (see 4.3.3) shall be immersed in JP-8 (in accordance with MIL-DTL-83133) at 73 °F for 70 hours. After immersion the samples shall be tested in accordance with ASTM D 751 for a minimum adhesion of 5 lbs/in. between the each layer of the composite drum wall. Nonconformance to table III shall constitute failure of this test.

4.6.8 Puncture resistance. A sample of the drum wall material (excluding the reinforced ends) shall be prepared according 4.3.3 and shall be puncture tested as specified in ASTM D 751. The 250 and 500 gallon drum walls shall withstand a force of not less than 325 pounds without being punctured. The 55 gallon drum wall shall withstand a force of not less than 200 pounds without being punctured. Nonconformance to 3.4.1 shall constitute failure of this test.

4.6.9 Weight. The emptied drum, with hardware, shall be weighed. Non-conformance with 3.4.2 shall constitute failure of this test.

4.6.10 Expansion (excluding Class I - Type III). The drum shall be filled with water to a pressure of 30 psig at an ambient temperature of 65 to 75 °F. The length and diameter shall be

measured within 15 minutes of filling. The length shall be measured by placing a 90° square upright at each end and measuring the distance between squares. The diameter shall be similarly measured by placing the square upright against each side at the center of the drum and measuring the distance between squares. The drum shall be maintained at 30 psig for 7 hours. At the end of the 7 hours, the measurements of length and diameter shall be repeated as described above. The difference between these final measurements and the original measurements shall be regarded as the change in dimensions. Nonconformance 3.4.3 shall constitute failure of this test.

4.6.11 Ultimate pressure. The 250 and 500 gallon drums shall be subjected to a hydrostatic pressure of 45 psig and allowed to stand for 30 minutes. The 55 gallon drum shall be subjected to a hydrostatic pressure of 35 psig and allowed to stand for 30 minutes. At the end of 5 minutes readjusted to 45 psig or 35 psig as applicable. After the hydrostatic test, the drum shall be emptied and visually examined both externally and internally. Nonconformance to 3.5.1 shall constitute failure of this test.

4.6.12 Proof pressure. The 250 and 500 gallon drums shall be subjected to a hydrostatic pressure of 30 psig and allowed to stand for 30 minutes. The 55 gallon drum shall be subjected to a hydrostatic pressure of 20 psig and allowed to stand for 30 minutes. At the end of 5 minutes readjusted to 30 psig or 20 psig as applicable. Nonconformance to 3.5.12 shall constitute failure of this test.

4.6.13 Ambient temperature collapsibility. The emptied drum shall be filled with a measured volume of water, then emptied using a suitable pump and subjected to a vacuum of not less than 12 inches of mercury.

Table VIII. Water volume for collapsibility test.

Class – Type by Capacity	Fill	Remove
500 gallon	465 gallons	435 gallons
250 gallon	240 gallons	210 gallons
55 gallon	45 gallons	35 gallons

This test shall be conducted at an ambient temperature of between 60 and 90 °F. With the drum in a horizontal position, the drum shall be filled and emptied through 75 cycles, (each filling and emptying constitutes one cycle). The drum shall be disassembled for examination of the drum liner. Nonconformance to 3.5.3 shall constitute failure of this test.

4.6.14 Leakage. Each drum shall be inflated with air to 6 ± 0.5 psig, and sprayed with soap or detergent sudsing solution over the entire surface to determine compliance with 3.5.4. If leaks are found, allow the drum to stand for 20 minutes to release trapped air and retest. Leakage shall be determined by observing areas for fizzing or bubbling of soap or detergent sudsing. Any evidence of fizzing or bubbling on the retest shall constitute failure of this test.

4.6.15 Drop (except Type III). The 500-gallon fuel drums shall be filled with at least 460 gallons of JP-8 in accordance with MIL-DTL-83133 (water may be substituted for JP-8 with consideration for the differences in density taken into account). The 500-gallon water drums

shall be filled with at least 475 gallons of water. The 250 gallon water drum shall be filled with at least 225 gallons of water. The drum shall then be lifted by the two of its lifting fittings until it has a minimum ground clearance of 5 feet for Class I drums and 12.7 feet for Class II drums. The drum shall free fall onto unprepared ground such as grass, sand, or bare earth. After the six free falls, the drum shall be visually examined for leaks, then emptied and visually examined, internally and externally, for evidence of broken hardware and separation of component layers of the drum body. The time between draining the water and completion of the six free falls shall not exceed 3 hours. Nonconformance to 3.5.5, any evidence of leakage or damage to the drum shall constitute failure of this test.

4.6.16 Rolling tow. The 500-gallon fuel drums shall be filled with at least 460 gallons of JP-8 in accordance with MIL-DTL-83133 (water may be substituted for JP-8 with consideration for the differences in density taken into account). The 500 gallon water drums shall be filled with not less than 475 gallons of water. The 250 gallon drum shall be filled with not less than 225 gallons of water. A suitable towing bar shall be attached to the tow/lift shackles on the drum. The drum shall be towed as a wheel for not less than 20 miles over a un-banked (level) paved road in less than 4 hours. The rate of speed of towing shall be between 5 to 10 miles per hour (mph). At the end of the tow test the drum shall be visually examined for defects. Presents of leakage, deform metal parts, exposed cords or fabric through the exterior liner, or delamination of the wall or reinforced end shall constitute failure of this test. Nonconformance to 3.5.6 shall constitute failure of this test.

4.6.17 Fuel storage test. The drum shall be fill with 500 gallons of JP-8 in accordance with MIL-DTL-83133 and allowed to stand for a minimum of 72 hours at ambient temperatures. At the end of each 24 hour period the drum shall be rotated 180 degrees and examined for leakage. Nonconformance to 3.5.7 shall constitute failure of this test.

4.6.18 Fuel/defuel valve test. This test shall be performed on Class II – Type I drums with a fuel/defuel valve installed. One fuel/defuel cycle shall consist of the following. The drum shall be filled to capacity at a minimum flow rate of 200 gallons per minute and a line pressure of 55 to 60 psig at the nozzle inlet by means of a D-1 nozzle conforming to SAE AS5877. Upon completion of filling, the pressure within the drum shall be observed to determine compliance with 3.6.3. The drum shall then be defueled by means of the D-1 nozzle to determine proper opening of the valve. Nonconformance to 3.6.3 shall constitute failure of this test.

4.6.19 Transportability.

a. Fill water drums to their rated capacity with water. Fill fuel drums with at least 420 gallons of water. The drum shall be lifted by one of its lifting, tiedown or tow points until it has a minimum ground clearance of one foot for a minimum of 24 hours. Visually examine the drum for leakage. Any evidence of leakage shall constitute failure of this test. Repeat this test for each lifting, tiedown or tow point. After all lifting, tiedown and tow points have subjected to the 24 hour test, disassemble the drum. Examine the drum internally and externally for the following defects; deform metal parts, broken hardware, separation of the drum body from metal parts, separations of any layer of the drum bodies composite material, delamination propagation blistering or leakage. Presence of any of these defects shall constitute failure of this test.

b. Static testing to simulate forces that drum transportability fittings would be subjected to under actual Helicopter Sling Load (HSL) conditions shall be acceptable. Forces shall be as determined by Mil-Std-209K. Test methods and results shall be approved by the U.S. Army Natick Research, Development and Engineering Center to obtain a HSL certification. Non-conformance to 3.6.4 shall constitute failure of this test.

c. Static testing to simulate forces that drum transportability fittings would be subjected to under actual Low Velocity Air Drop (LVAD) conditions shall be acceptable. Forces shall be as determined by Mil-Std-814D. Non-conformance to 3.6.4 shall constitute failure of this test.

5. PACKAGING

5.1 Packaging. For acquisition purposes, the packaging requirements shall be as specified in the contract order (see 6.2). When actual packaging of materiel is to be performed by DoD personnel, these personnel need to contact the responsible packaging activity to ascertain requisite packaging requirements. Packaging requirements are maintained by the Inventory Control Point's packaging activity within the Military Department or Defense Agency, or within the Military Department's System Command. Packaging data retrieval is available from the managing Military Department's or Defense Agency's automated packaging files, CD-ROM products, or by contacting the responsible packaging activity.

6. NOTES

(This section contains information of a general or explanatory nature which is helpful, but is not mandatory.)

6.1 Intended use. The Class I drums are intended for storing and transporting drinking (potable) water. The drums should not be used for any purpose other than storage and dispensing of drinking (potable) water. Class II drums are intended for storing and transporting fuel diesel fuel (A-A-52557) and JP-8 (MIL-DTL-83133).

6.2 Acquisition requirements. Acquisition documents must specify the following:

- a. Title, number, and date of this specification.
- b. Classification of drum required (see 1.2).
- c. Issue of DoDISS to be cited in the solicitation, and if required, the specific issue of individual documents referenced (see 2.2 and 2.3).
- d. When first article is required (see 3.2).
- e. When emergency repair kits are required (see 3.8).
- f. When accessories for Class I, Type II drums are not required (see 3.9).
- g. Packaging requirements (see 5.1).

6.3 First article. When a first article inspection is required, the item(s) should be a preproduction model. The first article should consist of two complete units and drum body material as specified in 4.3.3. The contracting officer should include specific instructions in

acquisition documents regarding arrangements for examinations, approval of the first article test results and disposition of the first articles. Invitation for bids should provide that the Government reserves the right to waive the requirement for samples for the first article inspection to those bidders offering a product that has been previously acquired or tested by the Government, and that bidders offering such products, who wish to rely on such production or test, must furnish evidence with the bid that prior Government approval is appropriate for the pending contract. Bidders should not submit alternate bids unless specifically requested to do so in the solicitation.

6.4 Documents. The documents listed below are cited as reference information only. They provide examples of equipment that has been found to be acceptable in the past. There is, however, no guarantee that this design will meet all the requirements. Contractors may use this design or provide a design of their own that must meet the performance requirements specified herein.

- TA13226E6030 - Drum, Fabric, Collapsible, Drinking Water, 250 Gallons. (Size I)
- TA13226E6040 - Drum, Fabric, Collapsible, Drinking Water, 500 Gallons. (Size II)
- TA13226E3190 - Drum, Fabric, Collapsible, Drinking Water, 500 Gallons, (4 inch Filler/Discharge). (Size IIA)
- TA13226E6020 - Drum, Fabric, Collapsible, Drinking Water, 55 Gallons. (Size III)
- TA13217E2990 - Drum, Fabric, Collapsible, Liquid fuel, 500 Gallon Capacity, Type I. (Longie).
- TA13216E9170 - Drum, Fabric, Collapsible, Liquid fuel, 500 Gallon Capacity, Type II. (Shortie).
- TA13227E6314 - Drum, Fabric, Collapsible, Liquid fuel, 500 Gallon Capacity, Type III (Shortie).
- 13216E9194
or equivalent - Valve, Fuel/Defuel
- 13216E9190 - Valve Assembly, 2 x 1-1/2
- 13229E8595 - Adapter Assembly

6.5 Subject term (key words) listing.

Blivet
 Drinking water
 Drum
 Elastomer
 Potable
 Fuel

ATPD 2295A
APPENDIX A

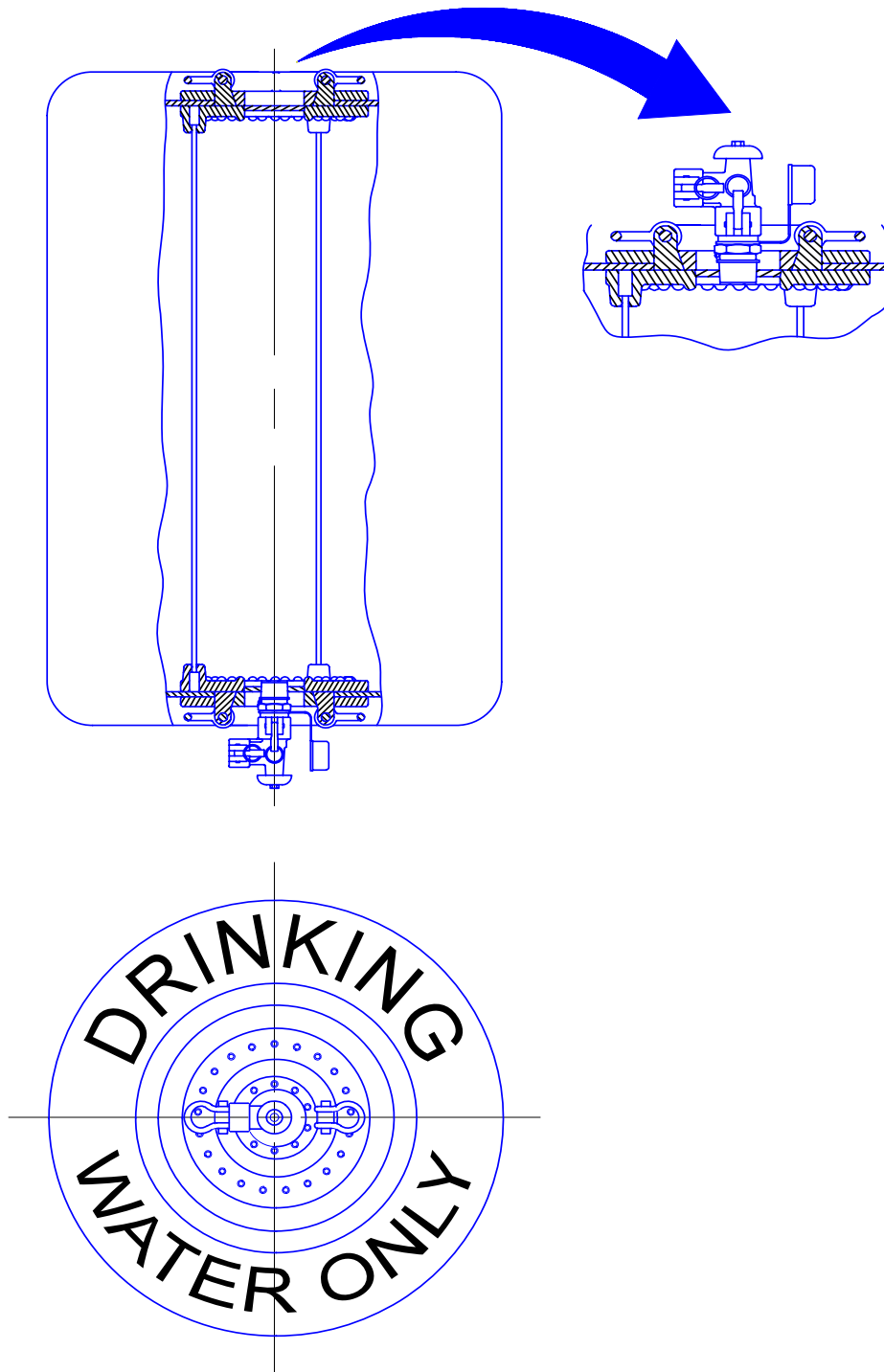

NOTES:

1. This figure contains no mandatory requirements. Final design of each drum is left to the contractor.
2. The configuration of the drum in this figure is representative of 250 and 500 gallon drums currently fielded and is provide for guidance only.

FIGURE A1. Drums, 500 and 250 Gallon Capacities.

ATPD 2295A
APPENDIX A

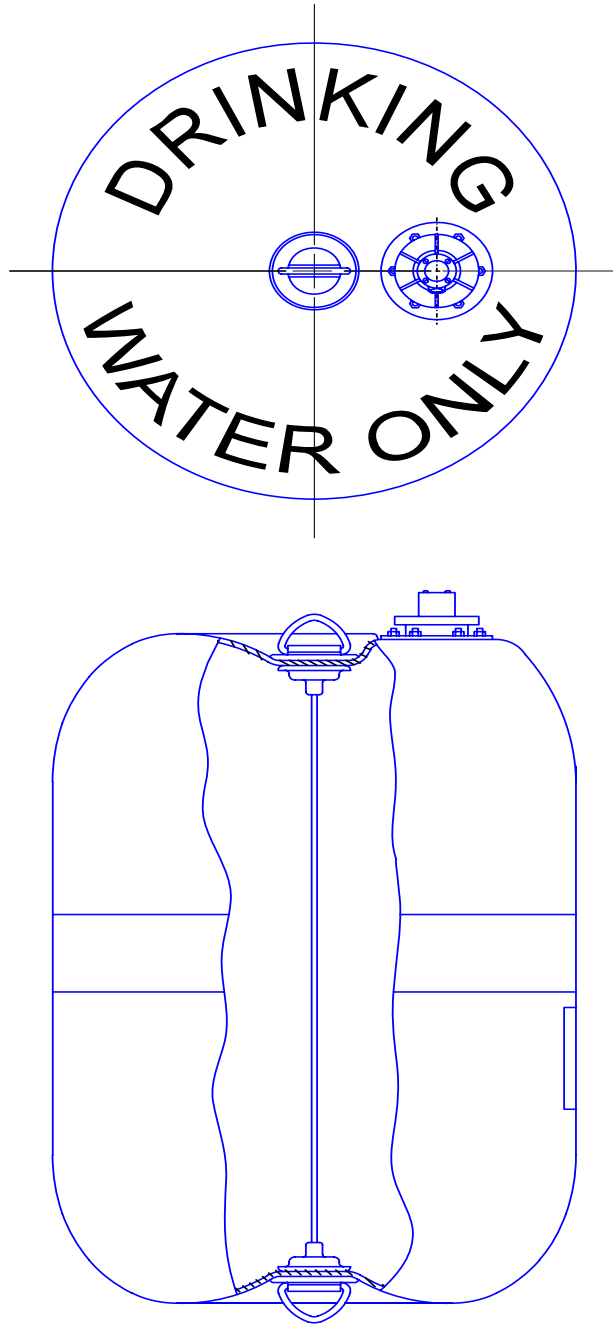

NOTES:

1. This figure contains no mandatory requirements. Final design of each drum is left to the contractor.
2. The configuration of the drum in this figure is representative of 55 gallon drums currently fielded and is provide for guidance only.

FIGURE A2. Drum, 55 Gallon Capacity.